

DRYING



Energy-efficient drying systems

LUXOR

 think materials management



LUXOR

CUSTOMER-ORIENTED DRYING SOLUTIONS FOR PLASTIC PROCESSORS



LUXOR central drying systems

Today, modern drying systems must be able to do more than just function reliably while operating in accordance with demanding specifications. They must also be economical, energy-efficient in operation and meet the very high requirements demanded for the manufacture of top quality finished products.

motan is continually striving to develop better and more energy-efficient ways to dry plastics. With the patented ETA-process® drying technology, motan had already set new standards. Now with the new ETA plus® technology, motan has taken another step forward. The system is a combination of the well-proven temperature adaptation and heat recovery systems, but now with a new dry airflow control which automatically considers variations in material throughput rates and material inlet temperatures. Compared with conventional drying systems, energy savings of up to 64 percent are possible.

Economy, reliability and quality

motan's drying systems are designed to operate at maximum efficiency and with minimal maintenance. The integration of dry-air conveying, line purging as well as manual and automatic manifold stations provide maximum flexibility and productivity. This means for the processor: maximum production time by minimising the downtime caused during material changes.

Proven and reliable drying technology using stationary desiccant beds and process heaters mounted directly at the drying bin enhances the efficiency of the drying process in every phase. It reduces heat loss and enables precise temperature control. motan's twin and three bed drying technology, in combination with closed-loop cool-down during regeneration, results in a constant low dew-point throughout the drying process.

With the combination of temperature adaptation, airflow control and the heat recovery system, the new ETA plus® technology guarantees precise temperature control and elimination of material degradation by ensuring that the plastic granulate is not over or under dried and offers considerable energy savings.



LUXOR central drying systems

motan's large range of LUXOR dryers is available in both standard and advanced versions.

The advanced LUXOR A series consists of ten models with a drying capacity from 80 to 2400 m³/h. Each advanced system dryer can be combined flexibly with all LUXORBIN A drying bins from 15 to 2400 litres.

The standard LUXOR S dryer series consists of four models with a dry-air capacity of 250 to 900 m³/h. These system dryers can be combined with all LUXORBIN S drying bins from 100 to 600 litres.

Furthermore, motan has a large assortment of different sized mobile LUXOR compact dryers and drying bins available ex stock.

LUXOR drying bins

The LUXORBIN drying bins are available in different sizes from 15 to 2400 litres. As standards, all motan system drying bins are made of stainless steel, are completely insulated, and have individual heating

as well as temperature control. The cylindrical shape of the bins ensures uniform drying of the material. A hinged lid enables easy access from above.

The larger system bins from 100 to 2400 litres are equipped with especially large clean-out doors fitted with a sight glass. They are formed to the shape of the bin in order to optimise material flow and simplify cleaning. The smaller bins with 15, 30 and 60 litres are equipped with a sight glass and cleaning is carried out via the hinged lid.

The bins are mounted on solid frames and have a control box mounted at the front of the bin for optimum accessibility. The long-life solid state relays guarantee precise and reliable temperature control that avoids damaging thermally-sensitive materials.

In addition, motan offers a range of extra large drying bins with volumes from 3,000 to 13,000 litres. These are also available with gas heating.

LUXOR

LUXOR 80-160



LUXOR 250-1200



LUXOR 1800-2400



LUXOR central drying systems

The LUXOR series dryers are equipped with either two or three fully insulated stationary desiccant beds. During regeneration, the air used to heat up the desiccant beds is pre-heated via a heat exchanger and so saves energy. Closed-loop after-cooling of the desiccant bed with dry air ensures a continuously low dew-point and maximum drying performance.

Tap the full energy-saving potential of ETA plus®

ETA plus® technology stands for innovative and energy-efficient drying technology which takes three individual factors into consideration:

- The airflow control adapts automatically to the amount of material being dried as well as to seasonal and time-of-day related fluctuations.
- Once the air flow has been reduced to its minimum value, the drying temperature adapts automatically to the amount of material being dried. This guarantees very gentle drying, especially when there is a large drop in material throughput rates.
- When drying with high temperatures, the heat recovery exchanger makes sense because it uses the high exhaust air temperatures to pre-heat the process air resulting in a significant reduction in energy consumption.

Altogether, the combination of airflow control and temperature reduction offers the highest possible energy savings. Compared with conventional drying systems, energy savings of up to 64 percent are possible.

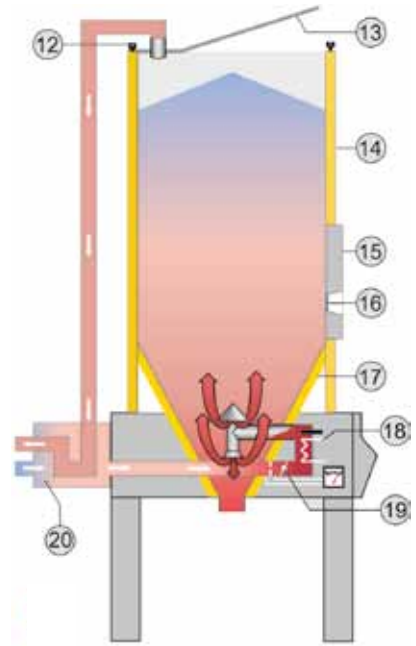
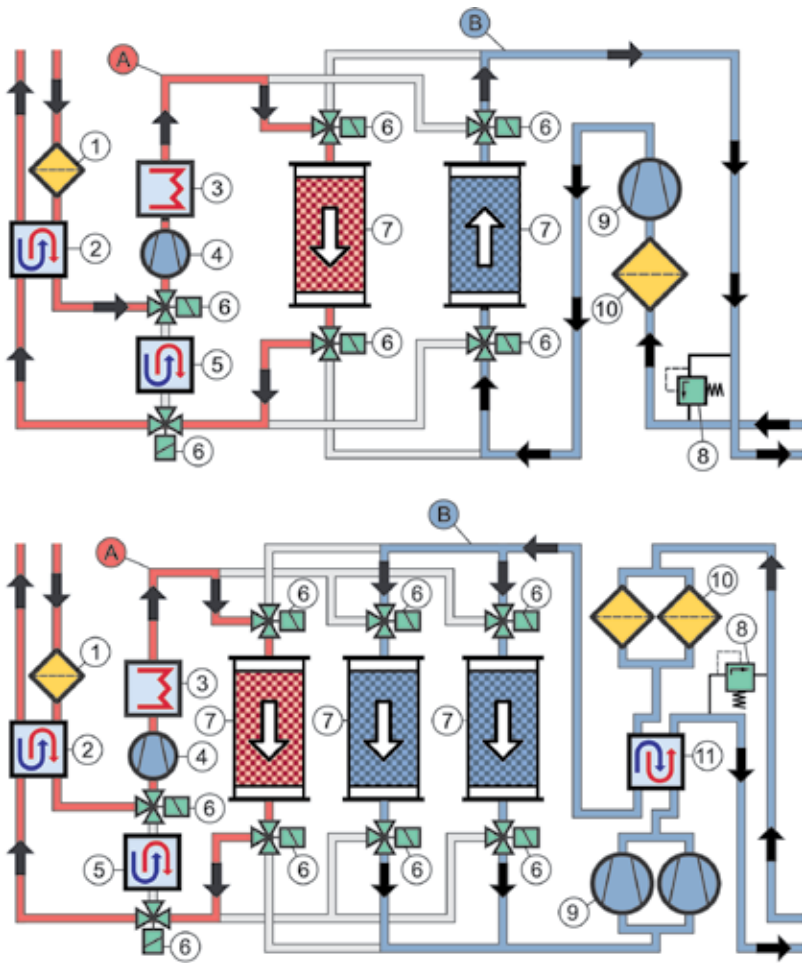

- Regeneration air circuit
 - Dry air circuit
- | | |
|---|-------------------------------|
| 1. Filter regeneration air | 12. Quick-release fastener |
| 2. Heat exchanger regeneration air | 13. Hinged lid |
| 3. Regeneration air heater | 14. Insulation |
| 4. Regeneration air blower | 15. Cleaning door |
| 5. Regeneration air cooler | 16. Sight glass |
| 6. Bed switching valves | 17. Additional insulation |
| 7. Desiccant beds | 18. Dry-air heater |
| 8. Safety valve | 19. Air regulation |
| 9. Dry-air blower | 20. Heat exchanger (optional) |
| 10. Return air filter | |
| 11. Heat exchanger process air (optional) | |

ETA plus® technology with heat recovery

Finding better ways to save energy has always been a focus for motan. For example, during regeneration when the desiccant beds are heated up, a heat exchanger is used to regain the energy from the hot moist exhaust air and to pre-heat the incoming air. Closed-loop cooling is then used in the cool-down phase so that only dry air is used. This saves energy and avoids moisture re-absorption prior to switch-over in the drying process.

With ETA plus® during drying, energy can be regained from the hot exhaust air leaving the drying bin through an optional heat exchanger. This is then used to pre-heat the process air resulting in large energy savings.

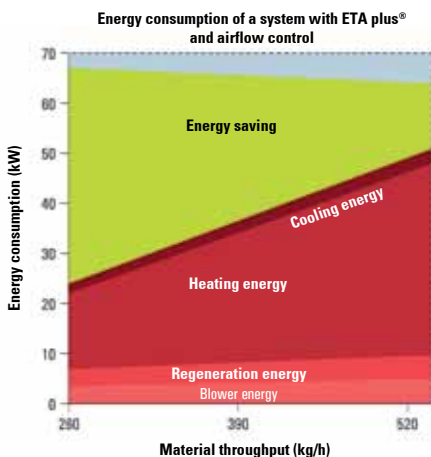

LUXOR dryers with ETA plus® technology

ETA plus® airflow control and temperature adaptation

If some materials are dried for too long or with temperatures which are too high, they can be thermally damaged. With ETA plus® technology, this is automatically avoided with a material throughput dependent airflow control and drying temperature adjustment. The system identifies material throughput variations or changed material inlet temperatures and adjusts the air flow automatically. When production is stopped, the drying temperature can be lowered to a standby temperature. The energy savings gained, as well as an alarm function when material throughputs are too high, are additional benefits offered by ETA plus® technology.

LUXOR

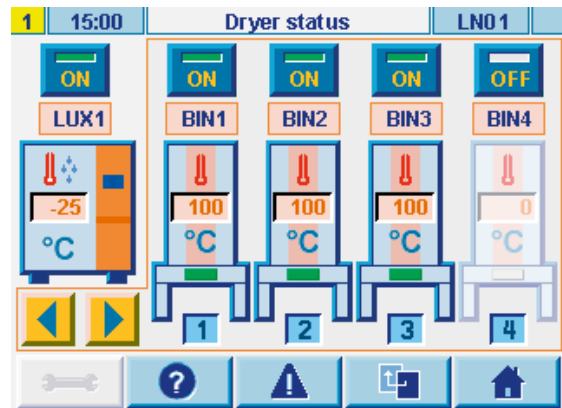
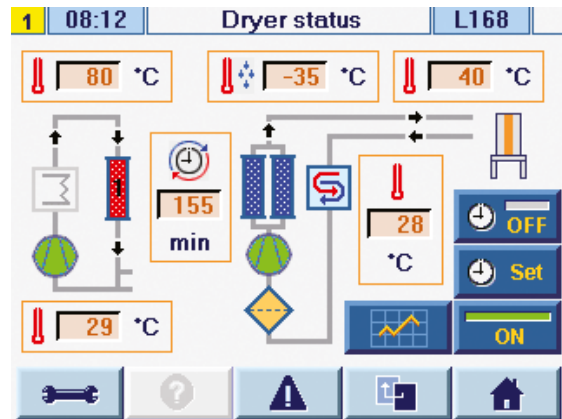

LUXOR controls

Operation, monitoring and data management are regulated by modern PLC-supported controls based on industrial PC's in accordance with IEC standards or using Siemens S7 technology. There are different types of dryer controls available - from an individual stand-alone dryer or networked via motan's Ethernet CONTROLnet as part of an integrated central system together with conveying systems and mixing and dosing units.

The LUXORnet control offers user-friendly operation via a colour graphic display with touch screen. LUXORnet incorporates comprehensive functions for operation and process control, recipe management, reporting for quality assurance as well as enhanced service functions and trend charts. The integrated DryingOrganizer function monitors the amount of material being dried and guarantees material-protective drying results by adjusting the drying temperature. ETA plus® airflow control with temperature adaptation is available as an option.

To simplify the input of the material-related drying parameters such as drying time and temperature, a material database is integrated in the control. The database includes a data pool with parameters for about 70 standard materials and can accommodate up to 100 data sets as specified by the customer.

All LUXOR A drying systems have a LUXORnet control and a modern, flexible BUS technology for 16 drying bins as well as for up to 24 machine hopper loaders.

LUXORnet technology stands out due to its modern, Ethernet-based open network architecture enabling standard networking with all other motan CONTROLnet controls.



Conveying

The hopper loaders on the drying bin are made of stainless steel and glass. They are equipped with a vacuum valve and an implosion valve for efficient filter cleaning after every conveying cycle.

Suction box

Conveying from the drying bin to the processing machine is done via a no-dead-space-suction box made of stainless steel with integrated purge facility guaranteeing very low residual moisture content and a constant material temperature. Dry-air conveying and line purging are available as an option.

Performance data

Material
(throughput rates)

| | Drying temp. (°C) | Residence time (h) | LB 15 | LB 30 | LB 60 | LB 100 | LB 150 | LB 250 | LB 400 | LB 600 | LB 900 | LB 1200 | LB 1800 | LB 2400 |
|--------------------------|-------------------|--------------------|-------|-------|-------|--------|--------|--------|--------|--------|--------|---------|---------|---------|
| ABS | 80 | 2-3 | 4 | 8 | 15 | 25 | 38 | 63 | 101 | 155 | 230 | 305 | 455 | 610 |
| CA | 75 | 2-3 | 3 | 6 | 11 | 19 | 28 | 46 | 74 | 115 | 170 | 225 | 335 | 450 |
| CAB | 75 | 2-3 | 3 | 5 | 10 | 17 | 25 | 42 | 67 | 100 | 150 | 200 | 300 | 400 |
| CP | 75 | 4 | 2 | 5 | 10 | 16 | 24 | 40 | 63 | 95 | 145 | 190 | 290 | 385 |
| EPDM | 80 | 4 | 2 | 4 | 8 | 13 | 20 | 33 | 53 | 80 | 120 | 160 | 240 | 320 |
| PA 6 | 75 | 4-6 | 2 | 4 | 8 | 14 | 20 | 34 | 54 | 85 | 125 | 165 | 245 | 330 |
| PA 6 40% GF | 80 | 4-6 | 3 | 6 | 12 | 20 | 31 | 51 | 82 | 125 | 185 | 245 | 370 | 490 |
| PA 6.10 / 66 | 80 | 4-6 | 2 | 4 | 8 | 14 | 20 | 34 | 54 | 85 | 125 | 165 | 245 | 330 |
| PA 6.11 | 80 | 6 | 2 | 3 | 6 | 10 | 16 | 26 | 41 | 65 | 95 | 125 | 190 | 250 |
| PAEK | 160 | 4 | 3 | 6 | 12 | 20 | 29 | 49 | 78 | 120 | 180 | 235 | 355 | 470 |
| PBT | 110 | 3 | 4 | 8 | 15 | 26 | 38 | 64 | 103 | 155 | 235 | 310 | 465 | 615 |
| PC | 120 | 3 | 4 | 8 | 15 | 26 | 38 | 64 | 103 | 155 | 235 | 310 | 465 | 615 |
| PE | 90 | 1-2 | 2 | 5 | 9 | 15 | 23 | 38 | 61 | 95 | 140 | 185 | 275 | 365 |
| PE black | 90 | 3 | 2 | 4 | 8 | 14 | 21 | 35 | 56 | 85 | 125 | 170 | 250 | 340 |
| PEEK | 150 | 3 | 4 | 8 | 15 | 26 | 38 | 64 | 103 | 155 | 235 | 310 | 465 | 615 |
| PEI | 150 | 3-4 | 3 | 6 | 12 | 20 | 29 | 49 | 78 | 120 | 180 | 235 | 355 | 470 |
| PES | 150 | 4 | 3 | 6 | 12 | 21 | 31 | 51 | 82 | 125 | 185 | 250 | 370 | 495 |
| PET (blow moulding) | 163 | 4-6 | 3 | 5 | 10 | 17 | 25 | 42 | 67 | 100 | 150 | 200 | 300 | 400 |
| PET (film) | 170 | 4-6 | 3 | 5 | 10 | 17 | 25 | 42 | 67 | 100 | 150 | 200 | 300 | 400 |
| PET (preforms) | 175 | 4-6 | 2 | 4 | 8 | 13 | 20 | 33 | 53 | 80 | 120 | 160 | 240 | 320 |
| PET (injection moulding) | 120 | 4 | 2 | 5 | 9 | 15 | 23 | 38 | 61 | 95 | 140 | 185 | 275 | 365 |
| PET G | 65 | 4-6 | 2 | 4 | 8 | 13 | 20 | 33 | 53 | 80 | 120 | 160 | 240 | 320 |
| PI | 140 | 2 | 5 | 9 | 18 | 30 | 45 | 76 | 121 | 185 | 275 | 365 | 545 | 730 |
| PMMA | 80 | 2-3 | 4 | 7 | 14 | 24 | 36 | 60 | 95 | 145 | 215 | 290 | 430 | 575 |
| POM | 110 | 2-3 | 4 | 8 | 17 | 28 | 42 | 69 | 111 | 170 | 250 | 335 | 500 | 670 |
| PP | 100 | 2-3 | 3 | 6 | 12 | 20 | 29 | 49 | 78 | 120 | 180 | 235 | 355 | 475 |
| PP talc 40% | 100 | 2-3 | 3 | 6 | 11 | 19 | 28 | 46 | 74 | 115 | 170 | 225 | 335 | 445 |
| PPO (PPE) | 110 | 2-3 | 4 | 8 | 15 | 26 | 38 | 64 | 102 | 155 | 230 | 310 | 465 | 615 |
| PPS | 140 | 3-4 | 3 | 7 | 14 | 23 | 35 | 58 | 93 | 140 | 210 | 280 | 420 | 555 |
| PS | 80 | 2 | 5 | 9 | 18 | 30 | 45 | 76 | 121 | 185 | 280 | 370 | 545 | 730 |
| PSU | 130 | 3-4 | 4 | 8 | 15 | 25 | 38 | 63 | 100 | 150 | 225 | 300 | 450 | 600 |
| PUR, TPU | 90 | 2-3 | 3 | 6 | 11 | 19 | 28 | 46 | 74 | 115 | 170 | 225 | 335 | 445 |
| PVC | 70 | 1-2 | 5 | 9 | 18 | 30 | 45 | 76 | 121 | 185 | 275 | 365 | 545 | 730 |
| SAN | 80 | 2-3 | 4 | 8 | 16 | 26 | 39 | 65 | 104 | 160 | 235 | 315 | 470 | 625 |
| SB | 80 | 2 | 4 | 8 | 17 | 28 | 42 | 69 | 111 | 170 | 250 | 335 | 500 | 670 |

The throughput rates indicated in the table are based on approx. values applicable to commercially available materials. Depending on bulk density, initial moisture and chosen drying parameters they can vary. Material throughput rates for extra large drying bins from 3,000 to 13,000 litres are available on request. Subject to technical changes.

LUXOR

TECHNICAL DATA

| Technical data | | | | | | | | | | |
|---|---------------|-------|-------|---------|---------|---------|---------|--------|--------|--------|
| Dry air generator Type LUXOR S & A | A 80 | A 120 | A 160 | A/S 250 | A/S 400 | A/S 600 | A/S 900 | A 1200 | A 1800 | A 2400 |
| Dry-air flow rate (m³/h) | 80 | 120 | 160 | 250 | 400 | 600 | 900 | 1200 | 1800 | 2400 |
| Connected load (kW) | 3.1 | 4.1 | 5.2 | 7.1 | 15.0 | 19.0 | 29.0 | 41.0 | 57.0 | 69.0 |
| Power supply (V/Hz) | 3/ /PE 400/50 | | | | | | | | | |
| Compressed air oil and water-free (bar) | 5 - 7 | | | | | | | | | |
| Dimensions | | | | | | | | | | |
| L1 | 550 | 550 | 550 | 800 | 1000 | 1350 | 1350 | 1600 | 1600 | 1600 |
| B1 | 920 | 920 | 920 | 850 | 1051 | 1268 | 1268 | 1270 | 2750 | 2750 |
| H1 | 1440 | 1440 | 1440 | 1650 | 2050 | 2190 | 2190 | 2190 | 2105 | 2105 |
| Ø d1 | 60 | 60 | 60 | 60 | 60 | 80 | 80 | 80 | 150 | 150 |
| Ø d2 | 60 | 60 | 60 | 100 | 100 | 150 | 150 | 150 | 300 | 300 |
| Weight approx. (kg)* | 176 | 183 | 194 | 320 | 520 | 900 | 1000 | 1200 | 2710 | 2860 |
| Colour RAL orange/grey | 2011/7040 | | | | | | | | | |

LUXOR 80-160

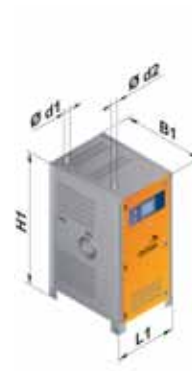

LUXOR 250-2400



| Technical data | | | | | | | | | | | | | |
|------------------------------------|---------------|--------|--------|-------------|-------------|-------------|---------------|-------------|-------------|--------------|--------------|--------------|------|
| Drying bins Type LUXORBIN A & S | LBA 15 | LBA 30 | LBA 60 | LBA LBS 100 | LBA LBS 150 | LBA LBS 250 | LBA LBS 400 | LBA LBS 600 | LBA LBS 900 | LBA LBS 1200 | LBA LBS 1800 | LBA LBS 2400 | |
| Drying bin volume (l) | 15 | 30 | 60 | 100 | 150 | 250 | 400 | 600 | 900 | 1200 | 1800 | 2400 | |
| Type L: Connected load (kW) | 1.0 | 1.0 | 1.5 | 1.5 | 1.5 | 3.0 | — | 4.5 | 6.0 | 10.5 | 10.5 | 21.0 | 31.5 |
| Max. drying temperature (°C) | 140 | 140 | 140 | 140 | 140 | 140 | — | 140 | 140 | 140 | 140 | 140 | 140 |
| Type H: Connected load (kW) | 1.0 | 1.0 | 1.5 | 1.5 | 3.0 | — | 4.5 | 6.0 | 9.0 | 21.0 | 21.0 | 31.5 | 42.0 |
| Max. drying temperature (°C) | 180 | 180 | 180 | 180 | 180 | — | 180 | 180 | 180 | 180 | 180 | 180 | 180 |
| Power supply (V/Hz) | 1/N/PE 230/50 | | | | | | 3/ /PE 400/50 | | | | | | |
| Dimensions (mm) | | | | | | | | | | | | | |
| L2 | 580 | 580 | 580 | 750 | 750 | 1000 | 1000 | 1000 | 1250 | 1250 | 1250 | 1500 | |
| H2 | 1180 | 1315 | 1503 | 1813 | 2148 | 2157 | 2548 | 2548 | 2755 | 3128 | 3413 | 3681 | |
| B2 | 600 | 600 | 600 | 915 | 915 | 1165 | 1165 | 1165 | 1415 | 1415 | 1415 | 1665 | |
| Ø d3 | 278 | 343 | 416 | 507 | 507 | 668 | 717 | 858 | 1017 | 1017 | 1176 | 1434 | |
| Weight approx. (kg)* | 60 | 65 | 72 | 125 | 135 | 185 | 230 | 250 | 350 | 380 | 460 | 815 | |
| Colour RAL orange/grey | 2011/7040 | | | | | | | | | | | | |

LUXORBIN A 15-60l

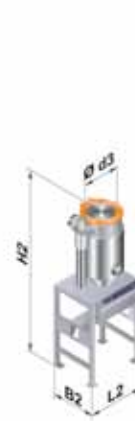

LUXORBIN A & S 100-2400l

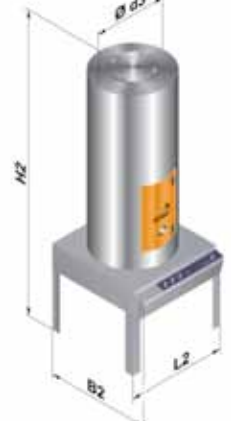

* Depending on equipment
 Technical data for extra large drying bins from 3,000 to 13,000 litres and electric/gas heaters are available on request

Over 130 agencies world-wide.

China, Beijing
 Tel. +86 10 8588-6968
 sales@motan-colortronic.com.cn

France, Evry
 Tel. +33 1 608 690-18
 info@motan-colortronic.fr

Germany, Isny
 Tel. +49 7562 76-0
 info@motan-colortronic.de

Italy, Milan
 Tel. +39 0292 1633 62
 info@motan-colortronic.it

Switzerland, Hunzenschwil
 Tel. +41 62 889 29-29
 info@motan-colortronic.ch

China, Guangzhou
 Tel. +86 20 2886-6688-8081
 sales@motan-colortronic.com.cn

Germany, Bünde
 Tel. +49 5223 68544-0
 info@motan-colortronic.de

Great Britain, Chesterfield
 Tel. +44 1 246 260 222
 sales@motan-colortronic.co.uk

Japan, Hiroshima
 Tel. +81 82 928-6150
 info@semco.jp

Thailand, Bangkok
 Tel. +66 2 717-1088
 info@motan.co.th

China, Taicang
 Tel. +86 512 5357-7066
 sales@motan-colortronic.com.cn

Germany, Friedrichsdorf
 Tel. +49 6175 792-167
 info@motan-colortronic.de

India, Chennai
 Tel. +91 44 2247-2423
 info@motan-colortronic.co.in

Singapore
 Tel. +65 6873-7666
 info@motan-colortronic.com.sg

USA, Plainwell
 Tel. +1 269 685-1050
 motanusa@motan-inc.com

www.motan-colortronic.com

